

MPTK-I

The MPTK-I pump is a highly efficient chopper pump designed for pumping heavily contaminated liquids as well as liquids with a high dry matter content, e.g. dewatered sludge.

All MPTK-I pumps are equipped with a knife system at the inlet to the pump, which ensures problem-free operations under conditions where many other pumps have problems with clogging

APPLICATION EXAMPLES

- Sewage treatment plants
- Pumping stations
- Biogas plants
- Food industry
- Pumping abrasive liquids or liquids with high viscosity

PUMP RPM

1,800 rpm

3,600 rpm



MATERIAL OF CONSTRUCTION

Motor housing and oil chamber	Cast iron AISI A48-40B
Pump housing	Cast iron AISI A48-40B
Pump impeller	Cast iron AISI A48-40B Cast iron AISI 100-70-03 (optional) Cast iron CF-8M (optional)
Pump shaft	AISI 4340
Bolts	Steel AISI 316
Sealing system	Mechanical shaft seals: silicon carbide/silicon carbide
Knife system	Hardened steel A 570 GR 36 (*) Acid-proof steel AISI 316 (optional)
Extended knife system	Hardened steel A 570 GR 36 (optional) Acid-proof steel AISI 316 (optional)
Oil type	15W-40 Vario HDX (with moisture detection)

(*) On the MPTK-I, the knife system is optional. The MPTK-I Ex includes the knife system

SERVICE AND MAINTENANCE

Recommended service interval/oil change	Maximum 2,000 operating hours/minimum once a year
Motor	Lifetime lubricated bearings
Oil chamber	Periodic oil change

SURFACE TREATMENT

Machinery enamel: RAL 9005 (Jet Black)	Jet Black
2-component coating: RAL 7005 (Mouse Grey) (optional)	Mouse Grey

MONITORING FUNCTIONS

Thermistor 284 °F

Moisture detection system (optional)

ELECTRICAL DATA

Motor type	3-phase AC motor
Nominal voltage	460 V
Minimum voltage allowed	415 V
Nominal frequency	60 Hz
Suitable for VFD-operation	Yes
Cage class	IP 55
Insulation class	F

Model	Nominal power	Motor	Full load current (460 V)	Connection method		Start current (DOL)	cos phi	Efficiency (100%)
	[HP]	[rpm]	[A]	[V]	Y/Δ	[A]		[%]
MPTK-I 50 1.2 HP-1800 rpm	1.2	1710	2.3	460	Y	11	0.68	74.0
MPTK-I 65 3.6 HP-1800 rpm	3.6	1720	5.3	460	Y	34	0.75	81.0
MPTK-I 80 9.0 HP-1800 rpm	9.0	1745	11.0	460	Δ	72	0.88	86.0
MPTK-I 105 17.9 HP-1800 rpm	17.9	1755	22.0	460	Δ	152	0.84	88.4
MPTK-I 105 30.2 HP-1800 rpm	30.2	1760	36.0	460	Δ	241	0.85	90.0
MPTK-I 150 35.4 HP-1800 rpm	35.4	1765	43.5	460	Δ	283	0.83	90.5
MPTK-I 150 48.9 HP-1800 rpm	48.9	1765	59.0	460	Δ	413	0.84	91.5

ELECTRICAL DATA

Motor type	3-phase AC motor
Nominal voltage	460 V
Minimum voltage allowed	415 V
Nominal frequency	60 Hz
Suitable for VFD-operation	Yes
Cage class	IP 55
Insulation class	F

Model	Nominal power	Motor	Full load current (460 V)	Connection method		Start current (DOL)	cos phi	Efficiency (100%)
	[HP]	[rpm]	[A]	[V]	Y/Δ	[A]		[%]
MPTK-I 50 9.0 HP-3600 rpm	9.0	3430	11.5	460	Δ	63	0.85	85.7
MPTK-I 65 17.9 HP-3600 rpm	17.9	3480	20.5	460	Δ	144	0.90	88.0
MPTK-I 65 30.2 HP-3600 rpm	30.2	3520	33.0	460	Δ	238	0.92	90.5
MPTK-I 80 30.2 HP-3600 rpm	30.2	3520	33.0	460	Δ	238	0.92	90.5
MPTK-I 80 35.4 HP-3600 rpm	35.4	3535	38.5	460	Δ	270	0.92	92.0
MPTK-I 80 48.9 HP-3600 rpm	48.9	3550	53.0	460	Δ	392	0.92	93.0

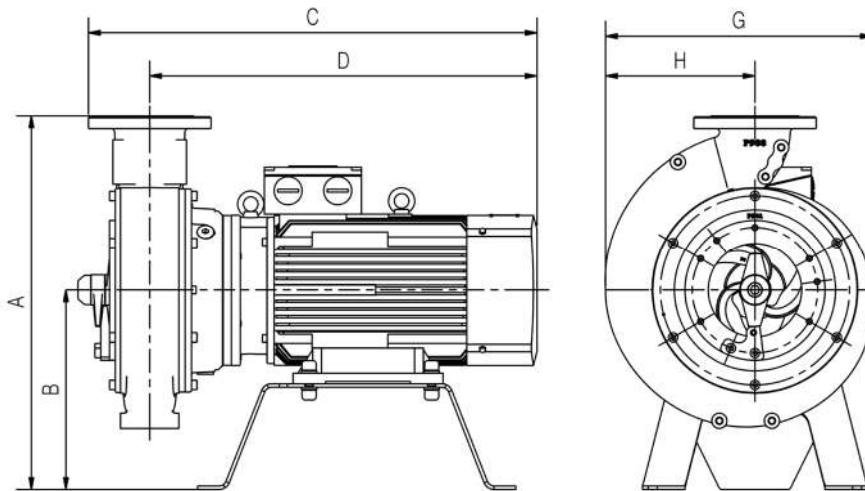
OVERALL DIMENSIONS

Model	A [inch]	B [inch]	C [inch]	D [inch]	G [inch]	H [inch]	Weight [lb]
MPTK-I 50 1.2 HP-1800 rpm	11.7	5.3	14.2	12.0	9.9	5.3	55
MPTK-I 65 3.6 HP-1800 rpm	17.9	9.8	19.3	16.1	12.6	6.9	121
MPTK-I 80 9.0 HP-1800 rpm	20.6	11.0	25.0	21.3	14.7	8.1	220
MPTK-I 105 17.9 HP-1800 rpm	25.2	13.4	28.4	24.2	18.1	9.8	353
MPTK-I 105 30.2 HP-1800 rpm	25.2	13.4	28.7	24.6	18.1	9.8	463
MPTK-I 150 35.4 HP-1800 rpm	32.5	15.0	34.4	28.6	22.9	12.6	728
MPTK-I 150 48.9 HP-1800 rpm	32.5	15.0	34.4	28.6	22.9	12.6	794

OVERALL DIMENSIONS

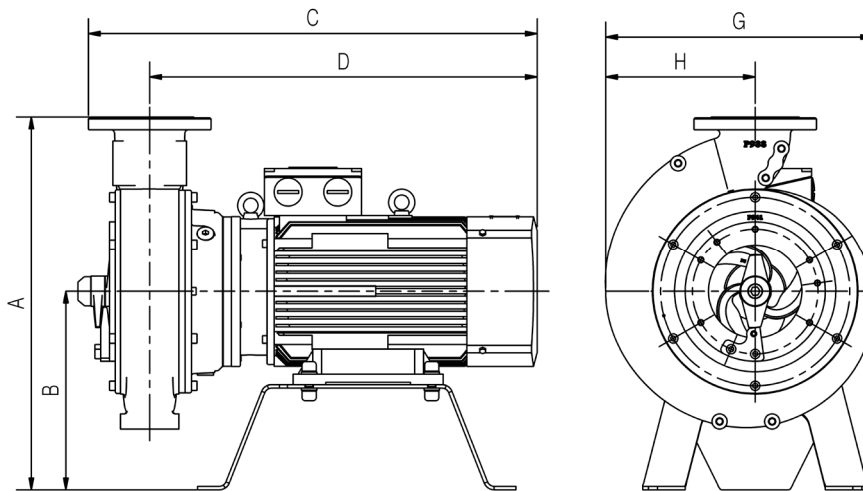

Model	A [inch]	B [inch]	C [inch]	D [inch]	G [inch]	H [inch]	Weight [lb]
MPTK-I 50 9.0 HP-3600 rpm	16.2	11.0	21.5	19.3	9.9	5.3	134
MPTK-I 65 17.9 HP-3600 rpm	21.5	13.4	25.7	22.5	12.6	6.9	231
MPTK-I 65 30.2 HP-3600 rpm	21.5	13.4	27.4	24.3	12.6	6.9	342
MPTK-I 80 30.2 HP-3600 rpm	24.5	15.0	28.3	24.6	14.6	8.1	452
MPTK-I 80 35.4 HP-3600 rpm	24.5	15.0	29.9	26.1	14.6	8.1	569
MPTK-I 80 48.9 HP-3600 rpm	24.5	15.0	31.7	28.0	14.6	8.1	672

We reserve the right to make technical alterations.

landiainc.com

Prepared by: BNV/GB
 Approved by: KSK/TM



Issued on: 15 March 2021
 Rev. date: